



SPECIFICATIONS

DISPLAY

- Liquid crystal display with backlight
- 4 line, 4 digits per line to show electrical Parameters
- 5th line, 8 digits to show energy
- Bar graph for current indication as a % of CT rating

LCD INDICATIONS

- I** - Integration of energy
- PRG** - Unit is in configuration menu -
- ↔** Communication in progress
- MAX DMD** - Maximum & Minimum Demand of Power

WIRING INPUT

- 3.Ø - 4 wire, 3.Ø - 3 wire, 2.Ø - 3 wire, 1.Ø - 2 wire

RATED INPUT VOLTAGE

- 11 to 300Vac (L-N); 19 to 519Vac (L-L)

FREQUENCY RANGE

- 45 - 65 Hz

CT PRIMARY

- 1A to 10000A (Programmable for any value)

CT SECONDARY

- Nominal 5A (min 11mA, Max 6A)

PT PRIMARY

- 100 to 500KVac (Programmable for any value)

PT SECONDARY

- 100 to 500Vac (Programmable for any value)

DISPLAY UPDATE TIME

- 1 Second for parameters

DISPLAY SCROLLING

- Automatic / Manual

POWER CONSUMPTION

- <8VA

TEMPERATURE

- Operating : -10 to 55°C
- Storage : -20 to 75°C

HUMIDITY

- 85% non-condensing

MOUNTING

- Panel mounting

WEIGHT

- 318gms

OUTPUT

- Pulsed Output : Voltage range External 24VDC max
- Current capacity : 100mA

INSTALLATION CATEGORY

- Category III

SERIAL COMMUNICATION

Interface Standard and protocol	RS485 & Modbus RTU
Communication address	1 to 255
Transmission Mode	Half duplex
Data types	Float and Integer
Transmission distance	500 Meter maximum
Transmission speed	300, 600, 1200, 2400, 4800 9600, 19200 (bps)
Parity	None, Odd, Even
Stop bits	1 or 2
Response time	100mS

Measurement	Accuracy
Voltage V _{L-N}	±0.5% of Full Scale
Voltage V _{L-L}	±0.5% of Full Scale
Current	±0.5% of Full Scale
Frequency	±0.1% of Full Scale For L-N Voltage >20V For L-L Voltage >35V
Active Power	1%
Reactive Power	1%
Apparent Power	1%
Power factor	±0.1%
Active Energy	Class 1
Reactive Energy	Class 1
Apparent Energy	Class 1
MAX / Min Active Power	1%
MAX / MIN Reactive Power	1%
MAX Apparent Power	1%

RESOLUTION

PT Ratio x CT Ratio	KWh / KVAh / KVArh	Pulse
<15	0.01K	0.01K
<150	0.1K	0.1K
<1500	1K	1K
<15000	0.01M	0.01M
<150000	0.1M	0.1M
≥1500000	1M	1M

- NOTE:
- For Voltage, Current, Power, resolution is automatically adjusted.
 - For Power Factor resolution is 0.001
 - I** Blink every 5 seconds, if a load is connected to at least 1 of the 3 phases

SAFETY PRECAUTIONS

All safety related codifications, symbols and instructions that appear in this operation manual or on the equipment must be strictly followed to ensure the safety of the operating personnel as well as the instrument.

If the equipment is not used in the manner specified by the manufacturer it might impair the protection provided by the equipment.



CAUTION

Read the instructions prior to installation and operation of the unit.



CAUTION

Risk of electrical shock

WIRING GUIDELINES



WARNING

- To prevent the risk of electric shock, power supply to the equipment must be kept OFF while installing the wiring.
- Wiring shall be done strictly according to the terminal layout. Confirm that all connections are correct.
- Use lugged terminals.
- To reduce electromagnetic interference use of wires with adequate ratings and twists of the same in equal size shall be made with shortest connections.
- Layout of connecting cables shall be away from any internal EMI source.
- Cable used for connection to power source, must have a cross section of 0.5mm² to 2.5mm². These wires shall have current capacity of 6A.
- Copper cable should be used (Stranded or single core cable).
- Before attempting work on the device ensure absence of voltages using appropriate voltage detection device.

INSTALLATION GUIDELINES



CAUTION

- This equipment, being of a built-in-type, normally becomes a part of a main control panel and in case the terminals do not remain accessible to the end user after installation and internal wire.
- Conductors must not come into contact with the internal circuitry of the equipment or it may lead to a safety hazard that may in turn endanger life or cause electrical shock to the operator.
- Protection & disconnection means must be installed between power source and supply terminals to facilitate power 'ON' or 'OFF' function & must be installed in a convenient position normally accessible to the operator.

SERIAL NUMBER DESCRIPTION

Press PF (**I**) key for 10 seconds to 8 digit serial number only for 10 seconds on the fifth line of the display

MECHANICAL INSTALLATION

For installing the meter

- Prepare the panel cut out with the dimensions as shown below.

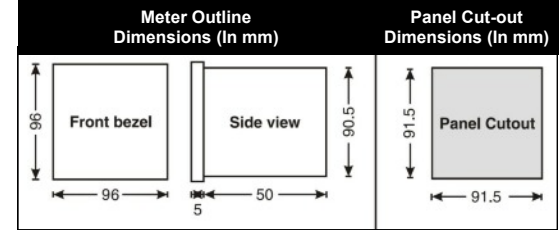

- Push the meter into the panel cut-out. Secure the meter in its place by fitting the clamp from the rear side. Fit clamps on both sides in diagonally opposite location for optimum fitting.
- For proper sealing, tighten the screws evenly with required torque.
- Recommended conductor cross section = 1.5mm².
- Screw clamps tightening torque = 0.1N-m



CAUTION

The equipment in its installed state must not be in close proximity to any heating sources, caustic vapour, oil, steam or other unwanted process by-products.

EMC Guidelines

- Use input power cable with shortest connections.
- Layout of connecting cables shall be away from any internal EMI source.

TERMINAL CONNECTIONS



CONNECTIONS DIAGRAM

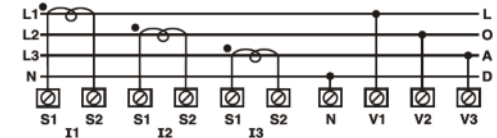

LEFT HAND CT MOUNTING PHASE CORRECTION

The meter phases L1, L2 & L3 are setup as default for the CT to be mounted as an incomer on the RH (Right Hand) side of the board. Meter display shows rH when "I" is pressed for 3 seconds. When the CT is mounted on the LH (Left Hand) side of the board the phase sequence needs to be reversed.

- Press "I" for 3 seconds, then release and then press again for 3 seconds. Phase will be reversed and the display will show LH.
- Wait 5 seconds for the meter to resume online reading. Meter display shows LH when "I" is pressed for 3 seconds.

ONLINE PAGE DESCRIPTION

There are 6 dedicated keys labelled as V, I, VAF, PF, P, E. Use these keys to read meter parameters.
Simply press these keys to read the parameters.

KEY PRESS	ONLINE PAGE DESCRIPTION
Press "V"	<p>The first screen (Page 1). Displays line to neutral voltage of three phases and average line to neutral voltage.</p> <p>The second screen (Page 2). Displays line to line voltage of three phases and average line to line voltage.</p> <p>The third screen (Page 3). Displays percentage harmonics line to neutral voltage of three phase and average percentage harmonic of line to neutral voltage.</p> <p>The fourth screen. (Page 4). Displays percentage harmonics of line to line voltage of three phase and average percentage harmonic of line to line voltage.</p> <p>The fifth screen. Press for 3 seconds. Displays phase sequence detection.</p> <p>Note: 1) In 3.Ø - 3W system only second and fourth pages will be available of selection phase. 2) In 1.Ø - 2W system only first, third and fifth pages will be available of selection phase.</p>
Press "I"	<p>The first screen (Page 5). Displays phase current of three phases and neutral current.</p> <p>The second screen (Page 6). Displays phase maximum current demand of three phase and average current.</p> <p>The third screen (Page 7). Displays percentage harmonics of current of three phase and average percentage harmonic of current.</p> <p>The fourth screen. Press for 3 seconds. Displays current correction indication page.</p> <p>Note: In 3.Ø - 3W system only first, second and third pages will be available of selection phase. Displays average current instead of neutral current.</p>
Press "VAF"	<p>The first screen (Page 8). Displays voltage, current, power factor of first phase and frequency.</p> <p>The second screen (Page 9). Displays voltage, current, power factor of second phase and frequency.</p> <p>The third screen (Page 10). Displays voltage, current, power factor of third phase and frequency.</p> <p>The fourth screen (Page 11). Displays average value of voltage, current, power factor of three phases and frequency.</p> <p>Note: 1) In 3.Ø - 3W system voltage, current, power factor and frequency will be line to line. 2) In 1.Ø - 2W system only first page will be available of selection phase.</p>
Press "PF"	<p>The first screen (Page 12). Displays power factor of three phase and average power factor.</p> <p>Note: 1) In 3.Ø - 3W system only power factor will be available of selection phase.</p>
Press "P"	<p>The first screen (Page 13). Displays active power of three phase and total active power.</p> <p>The second screen (Page 14). Displays reactive power of three phase and total reactive power.</p> <p>The third screen (Page 15). Displays reactive power of three phase and total apparent power.</p> <p>The second screen (Page 16). Displays active, reactive, apparent power and power factor of first phase.</p> <p>The fifth screen (Page 17). Displays active, reactive, apparent power and power factor of second phase.</p> <p>The sixth screen (Page 18). Displays active, reactive, apparent power and power factor of third phase.</p> <p>The seventh screen (Page 19). Displays total active, reactive, apparent power and average power factor of three phase.</p> <p>The eighth screen (Page 20). Displays maximum active, reactive, apparent power demand.</p> <p>The ninth screen (Page 21). Displays minimum active, reactive, apparent power demand.</p> <p>Note: 1) In 3.Ø - 3W system only seventh, eighth and ninth page will be available also for 1.Ø - 2W- system only first, second, third, fourth, eighth and ninth page will be available.</p>

KEY PRESS	ONLINE PAGE DESCRIPTION
Press "E"	<p>The first screen. Displays active energy of three phases.</p> <p>The second screen. Displays apparent energy of three phases.</p> <p>The third screen. Displays reactive energy of three Phases.</p>
<p>Note : For 1.Ø - 2W network, all pages will be the as 3.Ø - 4W only selected phase parameters will be displayed.</p>	

AUTOMATIC / MANUAL MODE DESCRIPTION

Press E (↔) key for 3 seconds to toggle between Automatic and Manual mode.
Note: By default unit operates in automatic mode.
In automatic mode online pages scroll automatically at the rate of 5 seconds per page.
In automatic mode when any key is pressed, unit temporarily switches to manual mode and the appropriate page is displayed, also if no key is pressed for 5 seconds the unit will return to automatic.

CONFIGURATION

There are 6 dedicated keys with symbols marked as ⏪, ⏩, ⏴, ⏵, ⏴, ⏵ use these 6 keys to enter into configuration menu or the change the settings.

Note : The settings should be done by a professional, after going through this users manual and after having understood the application situation.

For the configuration setting mode:

- Use ▲ + ▼ keys for 3 seconds to enter or exit from the configuration menu.
- Use ⏪ or ⏩ keys to move cursor left or right by one digit each time.
- Use ⏴ or ⏵ keys for increasing or decreasing parameter values.
- Use ⏴ key to go back to the previous page.
- Use ⏴ key to save the setting and move on to the next page.

Config. Page	Function	Range or Selection	Factory Setting
	Password	0000-9999	1000
1.0	Change Password	No/Yes	No
1.1	New Password	0000-9999	1000
2.0	Network Selection	3P4W, 3P3W 1P2W-P1 1P2W-P2 1P2W-P3	3P4W
3.0	CT Secondary	Pre-set	5A
4.0	CT Primary	5A to 10000A	160A
5.0	PT Secondary	173-415V	350V
6.0	PT Primary	100-500KV	350V
7.0	Slave ID (Address)	1-255	1
8.0	Baud Rate	300,600, 1200,4800, 9600 & 19200	9600
9.0	Parity	None, Even, Odd	None
10.0	Stop Bit	1 or 2	1

Config. Page	Function	Range or Selection	Factory Setting
11.0	Back Light	0-7200S	0000
12.0	Demand Interval Method	Sliding/Fixed	Sliding
13.0	Demand Interval Duration	1-30	15
14.0	Demand Interval Length	1-30min	1
15.0	Max Page Automatic	1-21	21
16	Change Page Sequence	No/Yes	No
16.01	Page Sequence 1	Page 1 of 21	1
16.02	Page Sequence 2	Page 2 of 21	2
16.03	Page Sequence 3	Page 3 of 21	3
16.04	Page Sequence 4	Page 4 of 21	4
16.05	Page Sequence 5	Page 5 of 21	5
16.06	Page Sequence 6	Page 6 of 21	6
16.07	Page Sequence 7	Page 7 of 21	7
16.08	Page Sequence 8	Page 8 of 21	8
16.09	Page Sequence 9	Page 9 of 21	9
16.10	Page Sequence 10	Page 10 of 21	10
16.11	Page Sequence 11	Page 11 of 21	11
16.12	Page Sequence 12	Page 12 of 21	12
16.13	Page Sequence 13	Page 13 of 21	13
16.14	Page Sequence 14	Page 14 of 21	14
16.15	Page Sequence 15	Page 15 of 21	15
16.16	Page Sequence 16	Page 16 of 21	16
16.17	Page Sequence 17	Page 17 of 21	17
16.18	Page Sequence 18	Page 18 of 21	18
16.19	Page Sequence 19	Page 19 of 21	19
16.20	Page Sequence 20	Page 20 of 21	20
16.21	Page Sequence 21	Page 21 of 21	21
17.0	Pulse Weight (KWh)	0.01 to 99.99	0.01
18.0	Pulse Duration (Seconds)	0.1 to 20	0.1
19.0	Factory Default	No/Yes	No
20.0	Reset Energy and Max Demand	No/Yes	No
*20.1	Password	0001-9999	1001
20.01	Reset Active Energy	No/Yes	No
20.02	Reset Reactive Energy	No/Yes	No
20.03	Reset Apparent Energy	No/Yes	No
20.04	Reset Max Current	No/Yes	No
20.05	Reset Max Active Power	No/Yes	No
20.06	Reset Min Active Power	No/Yes	No
20.07	Reset Max Reactive Power	No/Yes	No
20.08	Reset Min Reactive Power	No/Yes	No

Config. Page	Function	Range or Selection	Factory Setting
20.09	Reset Max Apparent Power	No/Yes	No

* For resetting energy parameters user will be prompted for password. If correct password is entered, the user will be able to reset all energy parameters. The password will be 1 greater than the main password.

APPLICATION OF PULSE OUTPUT

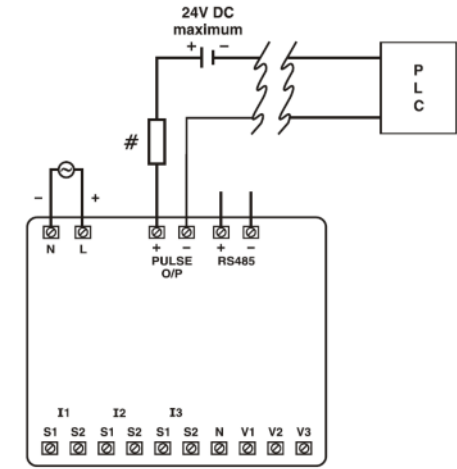

Pulse output from QC-POWER-P96 meter can be interfaced into a process through a PLC for the on-line control of energy content in the process. If the PLC has a self exciting digital input, an external DC voltage supply is not needed. The KWh pulse is also used to derive average KWh information at the PLC.

**# All fuse are : 0.5A Class CC UL type
0.5A fast acting 600VAc**

MODBUS REGISTER ADDRESSES LIST

Readable Parameters : [Length (Register) : 2 : Data Structure : Float]

Address	Hex Address	Parameter
30000	0x00	Voltage V1N
30002	0x02	Voltage V2N
30004	0x04	Voltage V3N
30006	0x06	Average Voltage LN
30008	0x08	Voltage V12
30010	0x0A	Voltage V23
30012	0x0C	Voltage V31
30014	0x0E	Average Voltage LL
30016	0x10	Current I1
30018	0x12	Current I2
30020	0x14	Current I3
30022	0x16	Average Current
30024	0x18	KW1
30026	0x1A	KW2
30028	0x1C	KW3
30030	0x1E	KVA1
30032	0x20	KVA2
30034	0x22	KVA3
30036	0x24	KVAr1
30038	0x26	KVAr2
30040	0x28	KVAr3
30042	0x2A	Total KW
30044	0x2C	Total KVA
30046	0x2E	Total KVAr
30048	0x30	PF1
30050	0x32	PF2
30052	0x34	PF3
30054	0x36	Average PF
30056	0x38	Frequency
30058	0x3A	Total Net KWh 30060
	0x3C	Total Net KVAh
30062	0x3E	Total Net KVArh
30064	0x40	KW Max Active Power
30066	0x42	KW Min Active Power
30068	0x44	KVAr Max Reactive Power
30070	0x46	KVAr Min Reactive Power
30072	0x48	KVA Max Apparent Power
30122	0x7A	Neutral Current
30124	0x7C	THD of 1st Phase Voltage
30126	0x7E	THD of 2nd Phase Voltage
30128	0x80	THD of 3rd Phase Voltage
30130	0x82	THD of Voltage V12
30132	0x84	THD of Voltage V23
30134	0x86	THD of Voltage V31
30136	0x88	THD of Current I1
30138	0x8A	THD of Current I2
30140	0x8C	THD of Current I3
30141	0x8D	1st Harmonic Voltage V1-N
30143	0x8F	2nd Harmonic Voltage V1-N
30145	0x91	3rd Harmonic Voltage V1-N

Address	Hex Address	Parameter
30147	0x93	4th Harmonic Voltage V1-N
30149	0x95	5th Harmonic Voltage V1-N
30151	0x97	6th Harmonic Voltage V1-N
30153	0x99	7th Harmonic Voltage V1-N
30155	0x9B	8th Harmonic Voltage V1-N
30157	0x9D	9th Harmonic Voltage V1-N
30159	0x9F	10th Harmonic Voltage V1-N
30161	0xA1	11th Harmonic Voltage V1-N
30163	0xA3	12th Harmonic Voltage V1-N
30165	0xA5	13th Harmonic Voltage V1-N
30167	0xA7	14th Harmonic Voltage V1-N
30169	0xA9	15th Harmonic Voltage V1-N
30171	0xAB	16th Harmonic Voltage V1-N
30173	0xAD	17th Harmonic Voltage V1-N
30175	0xAF	18th Harmonic Voltage V1-N
30177	0xB1	19th Harmonic Voltage V1-N
30179	0xB3	20th Harmonic Voltage V1-N
30181	0xB5	21st Harmonic Voltage V1-N
30183	0xB7	22nd Harmonic Voltage V1-N
30185	0xB9	23rd Harmonic Voltage V1-N
30187	0xBB	24th Harmonic Voltage V1-N
30189	0xBD	25th Harmonic Voltage V1-N
30191	0xBF	26th Harmonic Voltage V1-N
30193	0xC1	27th Harmonic Voltage V1-N
30195	0xC3	28th Harmonic Voltage V1-N
30197	0xC5	29th Harmonic Voltage V1-N
30199	0xC7	30th Harmonic Voltage V1-N
30201	0xC9	1st Harmonic Voltage V2-N
30203	0xCB	2nd Harmonic Voltage V2-N
30205	0xCD	3rd Harmonic Voltage V2-N
30207	0xCF	4th Harmonic Voltage V2-N
30209	0xD1	5th Harmonic Voltage V2-N
30211	0xD3	6th Harmonic Voltage V2-N
30213	0xD5	7th Harmonic Voltage V2-N
30215	0xD7	8th Harmonic Voltage V2-N
30217	0xD9	9th Harmonic Voltage V2-N
30219	0xDB	10th Harmonic Voltage V2-N
30221	0xDD	11th Harmonic Voltage V2-N
30223	0xDF	12th Harmonic Voltage V2-N
30225	0xE1	13th Harmonic Voltage V2-N
30227	0xE3	14th Harmonic Voltage V2-N
30229	0xE5	15th Harmonic Voltage V2-N
30231	0xE7	16th Harmonic Voltage V2-N
30233	0xE9	17th Harmonic Voltage V2-N
30235	0xEB	18th Harmonic Voltage V2-N
30237	0xED	19th Harmonic Voltage V2-N
30239	0xEF	20th Harmonic Voltage V2-N
30241	0xF1	21st Harmonic Voltage V2-N
30243	0xF3	22nd Harmonic Voltage V2-N
30245	0xF5	23rd Harmonic Voltage V2-N

Address	Hex Address	Parameter
30247	0xF7	24th Harmonic Voltage V2-N
30249	0xF9	25th Harmonic Voltage V2-N
30251	0xFB	26th Harmonic Voltage V2-N
30253	0xFD	27th Harmonic Voltage V2-N
30255	0xFF	28th Harmonic Voltage V2-N
30257	0x101	29th Harmonic Voltage V2-N
30259	0x103	30th Harmonic Voltage V2-N
30261	0x105	1st Harmonic Voltage V3-N
30263	0x107	2nd Harmonic Voltage V3-N
30265	0x109	3rd Harmonic Voltage V3-N
30267	0x10B	4th Harmonic Voltage V3-N
30269	0x10D	5th Harmonic Voltage V3-N
30271	0x10F	6th Harmonic Voltage V3-N
30273	0x111	7th Harmonic Voltage V3-N
30275	0x113	8th Harmonic Voltage V3-N
30277	0x115	9th Harmonic Voltage V3-N
30279	0x117	10th Harmonic Voltage V3-N
30281	0x119	11th Harmonic Voltage V3-N
30283	0x11B	12th Harmonic Voltage V3-N
30285	0x11D	13th Harmonic Voltage V3-N
30287	0x11F	14th Harmonic Voltage V3-N
30289	0x121	15th Harmonic Voltage V3-N
30291	0x123	16th Harmonic Voltage V3-N
30293	0x125	17th Harmonic Voltage V3-N
30295	0x127	18th Harmonic Voltage V3-N
30297	0x129	19th Harmonic Voltage V3-N
30299	0x12B	20th Harmonic Voltage V3-N
30301	0x12D	21st Harmonic Voltage V3-N
30303	0x12F	22nd Harmonic Voltage V3-N
30305	0x131	23rd Harmonic Voltage V3-N
30307	0x133	24th Harmonic Voltage V3-N
30309	0x135	25th Harmonic Voltage V3-N
30311	0x137	26th Harmonic Voltage V3-N
30313	0x139	27th Harmonic Voltage V3-N
30315	0x13B	28th Harmonic Voltage V3-N
30317	0x13D	29th Harmonic Voltage V3-N
30319	0x13F	30th Harmonic Voltage V3-N
30321	0x141	1st Harmonic Voltage V1-V2
30323	0x143	2nd Harmonic Voltage V1-V2
30325	0x145	3rd Harmonic Voltage V1-V2
30327	0x147	4th Harmonic Voltage V1-V2
30329	0x149	5th Harmonic Voltage V1-V2
30331	0x14B	6th Harmonic Voltage V1-V2
30333	0x14D	7th Harmonic Voltage V1-V2
30335	0x14F	8th Harmonic Voltage V1-V2
30337	0x151	9th Harmonic Voltage V1-V2
30339	0x153	10th Harmonic Voltage V1-V2
30341	0x155	11th Harmonic Voltage V1-V2
30343	0x157	12th Harmonic Voltage V1-V2
30345	0x159	13th Harmonic Voltage V1-V2

Address	Hex Address	Parameter
30347	0x15B	14th Harmonic Voltage V1-V2
30349	0x15D	15th Harmonic Voltage V1-V2
30351	0x15F	16th Harmonic Voltage V1-V2
30353	0x161	17th Harmonic Voltage V1-V2
30355	0x163	18th Harmonic Voltage V1-V2
30357	0x165	19th Harmonic Voltage V1-V2
30359	0x167	20th Harmonic Voltage V1-V2
30361	0x169	21st Harmonic Voltage V1-V2
30363	0x16B	22nd Harmonic Voltage V1-V2
30365	0x16D	23rd Harmonic Voltage V1-V2
30367	0x16F	24th Harmonic Voltage V1-V2
30369	0x171	25th Harmonic Voltage V1-V2
30371	0x173	26th Harmonic Voltage V1-V2
30373	0x175	27th Harmonic Voltage V1-V2
30375	0x177	28th Harmonic Voltage V1-V2
30377	0x179	29th Harmonic Voltage V1-V2
30379	0x17B	30th Harmonic Voltage V1-V2
30381	0x17D	1st Harmonic Voltage V2-V3
30383	0x17F	2nd Harmonic Voltage V2-V3
30385	0x181	3rd Harmonic Voltage V2-V3
30387	0x183	4th Harmonic Voltage V2-V3
30389	0x185	5th Harmonic Voltage V2-V3
30391	0x187	6th Harmonic Voltage V2-V3
30393	0x189	7th Harmonic Voltage V2-V3
30395	0x18B	8th Harmonic Voltage V2-V3
30397	0x18D	9th Harmonic Voltage V2-V3
30399	0x18F	10th Harmonic Voltage V2-V3
30401	0x191	11th Harmonic Voltage V2-V3
30403	0x193	12th Harmonic Voltage V2-V3
30405	0x195	13th Harmonic Voltage V2-V3
30407	0x197	14th Harmonic Voltage V2-V3
30409	0x199	15th Harmonic Voltage V2-V3
30411	0x19B	16th Harmonic Voltage V2-V3
30413	0x19D	17th Harmonic Voltage V2-V3
30415	0x19F	18th Harmonic Voltage V2-V3
30417	0x1A1	19th Harmonic Voltage V2-V3
30419	0x1A3	20th Harmonic Voltage V2-V3
30421	0x1A5	21st Harmonic Voltage V2-V3
30423	0x1A7	22nd Harmonic Voltage V2-V3
30425	0x1A9	23rd Harmonic Voltage V2-V3
30427	0x1AB	24th Harmonic Voltage V2-V3
30429	0x1AD	25th Harmonic Voltage V2-V3
30431	0x1AF	26th Harmonic Voltage V2-V3
30433	0x1B1	27th Harmonic Voltage V2-V3
30435	0x1B3	28th Harmonic Voltage V2-V3
30437	0x1B5	29th Harmonic Voltage V2-V3
30439	0x1B7	30th Harmonic Voltage V2-V3
30441	0x1B9	1st Harmonic Voltage V3-V1
30443	0x1BB	2nd Harmonic Voltage V3-V1
30445	0x1BD	3rd Harmonic Voltage V3-V1

MODBUS REGISTER ADDRESSES LIST

Readable Parameters : [Length (Register) : 2 : Data Structure : Float]

Address	Hex Address	Parameter
30447	0x1BF	4th Harmonic Voltage V3-V1
30449	0x1C1	5th Harmonic Voltage V3-V1
30451	0x1C3	6th Harmonic Voltage V3-V1
30453	0x1C5	7th Harmonic Voltage V3-V1
30455	0x1C7	8th Harmonic Voltage V3-V1
30457	0x1C9	9th Harmonic Voltage V3-V1
30459	0x1CB	10th Harmonic Voltage V3-V1
30461	0x1CD	11th Harmonic Voltage V3-V1
30463	0x1CF	12th Harmonic Voltage V3-V1
30465	0x1D1	13th Harmonic Voltage V3-V1
30467	0x1D3	14th Harmonic Voltage V3-V1
30469	0x1D5	15th Harmonic Voltage V3-V1
30471	0x1D7	16th Harmonic Voltage V3-V1
30473	0x1D9	17th Harmonic Voltage V3-V1
30475	0x1DB	18th Harmonic Voltage V3-V1
30477	0x1DD	19th Harmonic Voltage V3-V1
30479	0x1DF	20th Harmonic Voltage V3-V1
30481	0x1E1	21st Harmonic Voltage V3-V1
30483	0x1E3	22nd Harmonic Voltage V3-V1
30485	0x1E5	23rd Harmonic Voltage V3-V1
30487	0x1E7	24th Harmonic Voltage V3-V1
30489	0x1E9	25th Harmonic Voltage V3-V1
30491	0x1EB	26th Harmonic Voltage V3-V1
30493	0x1ED	27th Harmonic Voltage V3-V1
30495	0x1EF	28th Harmonic Voltage V3-V1
30497	0x1F1	29th Harmonic Voltage V3-V1
30499	0x1F3	30th Harmonic Voltage V3-V1
30501	0x1F5	1st Harmonic Current I1
30503	0x1F7	2nd Harmonic Current I1
30505	0x1F9	3rd Harmonic Current I1
30507	0x1FB	4th Harmonic Current I1
30509	0x1FD	5th Harmonic Current I1
30511	0x1FF	6th Harmonic Current I1
30513	0x201	7th Harmonic Current I1
30515	0x203	8th Harmonic Current I1
30517	0x205	9th Harmonic Current I1
30519	0x207	10th Harmonic Current I1
30521	0x209	11th Harmonic Current I1
30523	0x20B	12th Harmonic Current I1
30525	0x20D	13th Harmonic Current I1
30527	0x20F	14th Harmonic Current I1
30529	0x211	15th Harmonic Current I1
30531	0x213	16th Harmonic Current I1
30533	0x215	17th Harmonic Current I1
30535	0x217	18th Harmonic Current I1
30537	0x219	19th Harmonic Current I1
30539	0x21B	20th Harmonic Current I1
30541	0x21D	21st Harmonic Current I1
30543	0x21F	22nd Harmonic Current I1
30545	0x221	23rd Harmonic Current I1

Address	Hex Address	Parameter
30547	0x223	24th Harmonic Current I1
30549	0x225	25th Harmonic Current I1
30551	0x227	26th Harmonic Current I1
30553	0x229	27th Harmonic Current I1
30555	0x22B	28th Harmonic Current I1
30557	0x22D	29th Harmonic Current I1
30559	0x22F	30th Harmonic Current I1
30561	0x231	1st Harmonic Current I2
30563	0x233	2nd Harmonic Current I2
30565	0x235	3rd Harmonic Current I2
30567	0x237	4th Harmonic Current I2
30569	0x239	5th Harmonic Current I2
30571	0x23B	6th Harmonic Current I2
30573	0x23D	7th Harmonic Current I2
30575	0x23F	8th Harmonic Current I2
30577	0x241	9th Harmonic Current I2
30579	0x243	10th Harmonic Current I2
30581	0x245	11th Harmonic Current I2
30583	0x247	12th Harmonic Current I2
30585	0x249	13th Harmonic Current I2
30587	0x24B	14th Harmonic Current I2
30589	0x24D	15th Harmonic Current I2
30591	0x24F	16th Harmonic Current I2
30593	0x251	17th Harmonic Current I2
30595	0x253	18th Harmonic Current I2
30597	0x255	19th Harmonic Current I2
30599	0x257	20th Harmonic Current I2
30601	0x259	21st Harmonic Current I2
30603	0x25B	22nd Harmonic Current I2
30605	0x25D	23rd Harmonic Current I2
30607	0x25F	24th Harmonic Current I2
30609	0x261	25th Harmonic Current I2
30611	0x263	26th Harmonic Current I2
30613	0x265	27th Harmonic Current I2
30615	0x267	28th Harmonic Current I2
30617	0x269	29th Harmonic Current I2
30619	0x26B	30th Harmonic Current I2
30621	0x26D	1st Harmonic Current I3
30623	0x26F	2nd Harmonic Current I3
30625	0x271	3rd Harmonic Current I3
30627	0x273	4th Harmonic Current I3
30629	0x275	5th Harmonic Current I3
30631	0x277	6th Harmonic Current I3
30633	0x279	7th Harmonic Current I3
30635	0x27B	8th Harmonic Current I3
30637	0x27D	9th Harmonic Current I3
30639	0x27F	10th Harmonic Current I3
30641	0x281	11th Harmonic Current I3
30643	0x283	12th Harmonic Current I3
30645	0x285	13th Harmonic Current I3

Address	Hex Address	Parameter
30647	0x287	14th Harmonic Current I3
30649	0x289	15th Harmonic Current I3
30651	0x28B	16th Harmonic Current I3
30653	0x28D	17th Harmonic Current I3
30655	0x28F	18th Harmonic Current I3
30657	0x291	19th Harmonic Current I3
30659	0x293	20th Harmonic Current I3
30661	0x295	21st Harmonic Current I3
30663	0x297	22nd Harmonic Current I3
30665	0x299	23rd Harmonic Current I3
30667	0x29B	24th Harmonic Current I3
30669	0x29D	25th Harmonic Current I3
30671	0x29F	26th Harmonic Current I3
30673	0x2A1	27th Harmonic Current I3
30675	0x2A3	28th Harmonic Current I3
30677	0x2A5	29th Harmonic Current I3
30679	0x2A7	30th Harmonic Current I3
30684	0x2AC	Serial N° (Data Structure : Hex)
30692	0x2B4	Max I1 Demand
30694	0x2B6	Max I2 Demand
30696	0x2B8	Max I3 Demand
30700	0x2BC	Phase Sequence Indication
30702	0x2BE	Existing KW MAX Active Power
30704	0x2C0	Existing KW MIN Active Power
30706	0x2C2	Existing KVAR MAX Reactive Power
30708	0x2C4	Existing KVAR MIN Reactive Power
30710	0x2C6	Existing KVA MAX Apparent Power
30712	0x2C8	Existing MAX I1 Demand
30714	0x2CA	Existing MAX I2 Demand
30716	0x2CC	Existing MAX I3 Demand
30718	0x2CE	Existing MAX Average I Demand

CONNECTION DIAGRAM FOR COMMUNICATION

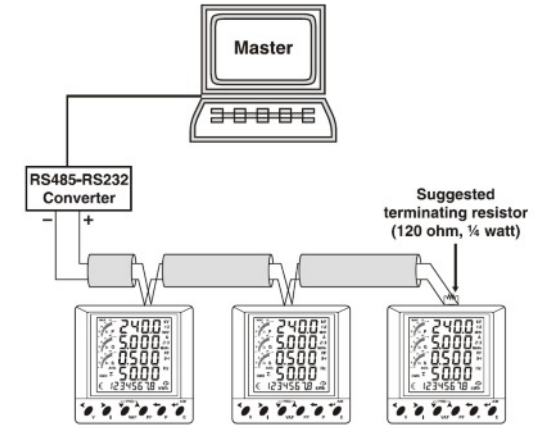

Contact sales for PC based monitoring software to communicate with the meters.

MODBUS REGISTER ADDRESSES LIST

Readable / Writable Parameters : [Data Structure : Integer]

Address	Hex Address	Parameter	Range		Length (Register)
			Min Value	Max Value	
40000	0x00	Password	0	9998	1
			Value	Meaning	
40001	0x01	Network Selection	0x0000	3P4W	1
			0x0001	3P3W	1
			0x0002	1P2W-P1	1
			0x0003	1P2W-P2	1
			0x0004	1P2W-P3	1
			Min Value	Max Value	
40002	0x02	CT Secondary	1	5	1
40003	0x03	CT Primary (CT Secondary = 5A)	5	10000	1
		CT Primary (CT Secondary = 1A)	1	10000	
40004	0x04	PT Secondary	173	415	1
40005	0x05	PT Primary	100	500000	2
40007	0x07	Slave ID	1	255	1
			Value	Meaning	
40008	0x08	Baud Rate	0x0000	300 bps	1
			0x0001	600 bps	1
			0x0002	1200 bps	1
			0x0003	2400 bps	1
			0x0004	4800 bps	1
			0x0005	9600 bps	1
			0x0006	19200 bps	1
40009	0x09	Parity	0x0000	None	1
			0x0001	Odd	1
			0x0002	Even	1
40010	0x0A	Stop Bit	0x0000	1	1
			0x000	2	1
			Min Value	Max Value	
40011	0x0B	Backlight OFF	0	7200	1
40012	0x0C	Factory Default Reset	1	Set to factory setting range	1
40013	0x0D	Reset KWh	1	Reset Total Active Energy	1
40014	0x0E	Reset KVAh	1	Reset Total Apparent Energy	1
40015	0x0F	Reset KVArh	1	Reset Total Reactive Energy	1
40016	0x10	Auto Mode Pages	1	21	1
			Page N°	Meaning	
40017	0x11	Page Address Sequence	1-21	1-First Page : 21-Last Page	1
40018	0x12	Page Address Sequence	1-21	1-First Page : 21-Last Page	1

Address	Hex Address	Parameter	Range		Length (Register)
			Min Value	Max Value	
40019	0x13	Page Address Sequence	1-21	1-First Page : 21-Last Page	1
40020	0x14	Page Address Sequence	1-21	1-First Page : 21-Last Page	1
40021	0x15	Page Address Sequence	1-21	1-First Page : 21-Last Page	1
40022	0x16	Page Address Sequence	1-21	1-First Page : 21-Last Page	1
40023	0x17	Page Address Sequence	1-21	1-First Page : 21-Last Page	1
40024	0x18	Page Address Sequence	1-21	1-First Page : 21-Last Page	1
40025	0x19	Page Address Sequence	1-21	1-First Page : 21-Last Page	1
40026	0x1A	Page Address Sequence	1-21	1-First Page : 21-Last Page	1
40027	0x1B	Page Address Sequence	1-21	1-First Page : 21-Last Page	1
40028	0x1C	Page Address Sequence	1-21	1-First Page : 21-Last Page	1
40028	0x1D	Page Address Sequence	1-21	1-First Page : 21-Last Page	1
40030	0x1E	Page Address Sequence	1-21	1-First Page : 21-Last Page	1
40031	0x1F	Page Address Sequence	1-21	1-First Page : 21-Last Page	1
40032	0x20	Page Address Sequence	1-21	1-First Page : 21-Last Page	1
40033	0x21	Page Address Sequence	1-21	1-First Page : 21-Last Page	1
40054	0x36	Page Address Sequence	1-21	1-First Page : 21-Last Page	1
40055	0x37	Page Address Sequence	1-21	1-First Page : 21-Last Page	1
40059	0x3B	Page Address Sequence	1-21	1-First Page : 21-Last Page	1
40060	0x3C	Page Address Sequence	1-21	1-First Page : 21-Last Page	1
			Value	Meaning	
40034	0x22	Demand Interval Method	0x0000	Sliding	1
			0x0001	Fixed	1
40035	0x23	Demand Interval Duration	Min 1	Max 30	1
40036	0x24	Demand interval Length	Min 1	Max 30	1
40037	0x25	Reset Max KW	1	Reset Max Active Power	1
40038	0x26	Reset Min KW	1	Reset Min Active Power	1
40039	0x27	Reset Max KVAh	1	Reset Max Reactive Power	1
40040	0x28	Reset Min KVAh	1	Reset Max Reactive Power	1
40041	0x29	Reset Max KVA	1	Reset Max Apparent Power	1
			Min Value	Max Value	
40057	0x39	Pulse Duration	0.1(second)	2.0(seconds)	1
40058	0x3A	Pulse Weight	00.10	99.99	1
			Value	Meaning	
40064	0x40	Reset Max Current	1	Reset Max Current	1

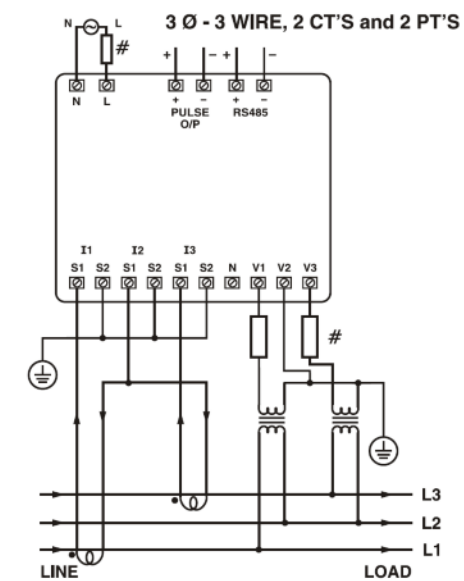
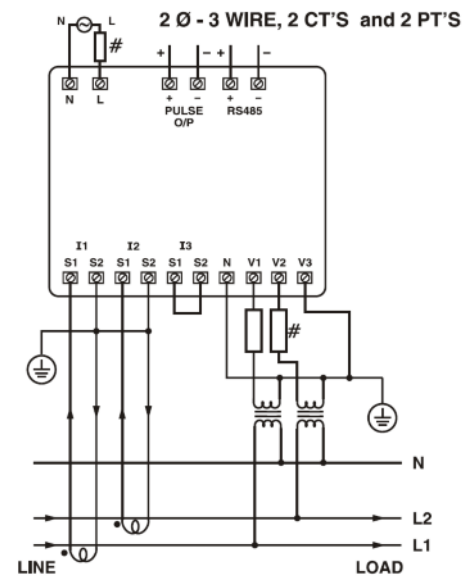
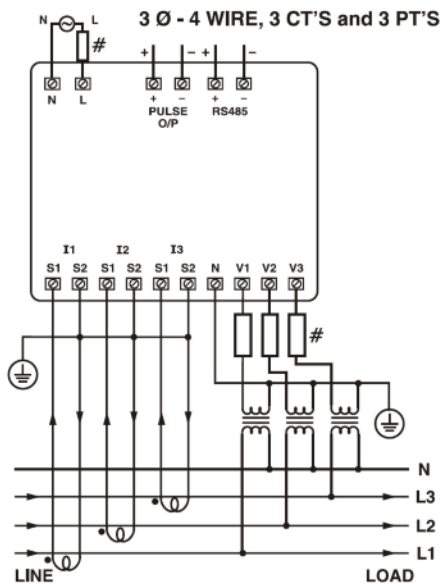
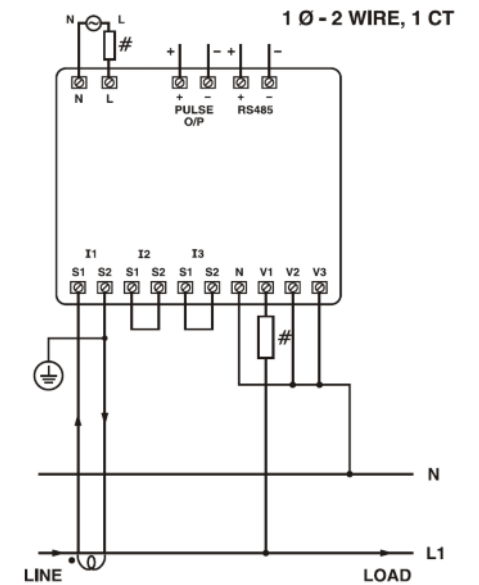
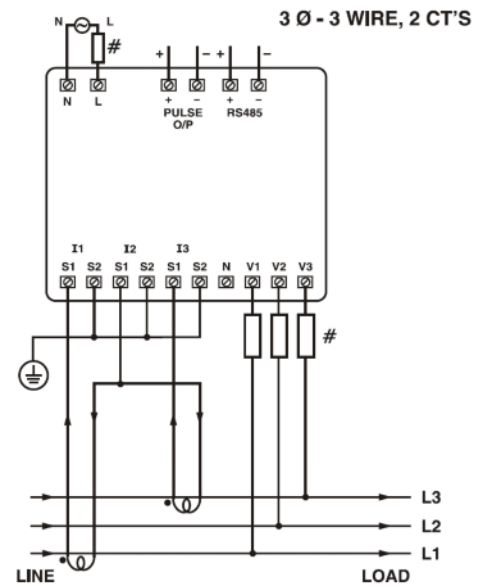
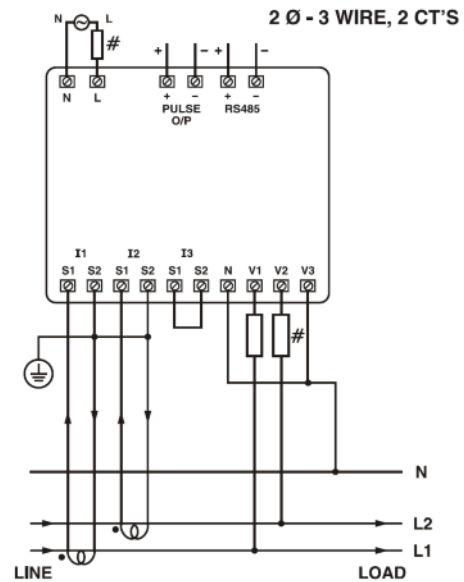
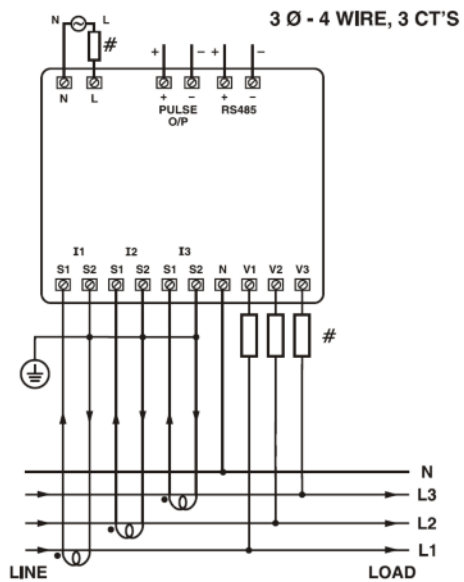

All fuse types : 0.5A class CC UL type
0.5A fast acting 600V



D.E.M. Spa – Z.I. Villanova, 20
32013 Longarone (BL) Italy
www.qeed.it